

INSTALLATION AND OPERATION MANUAL ENVIRONMENTAL SYSTEM 1000 MODEL 1204 AND 1208

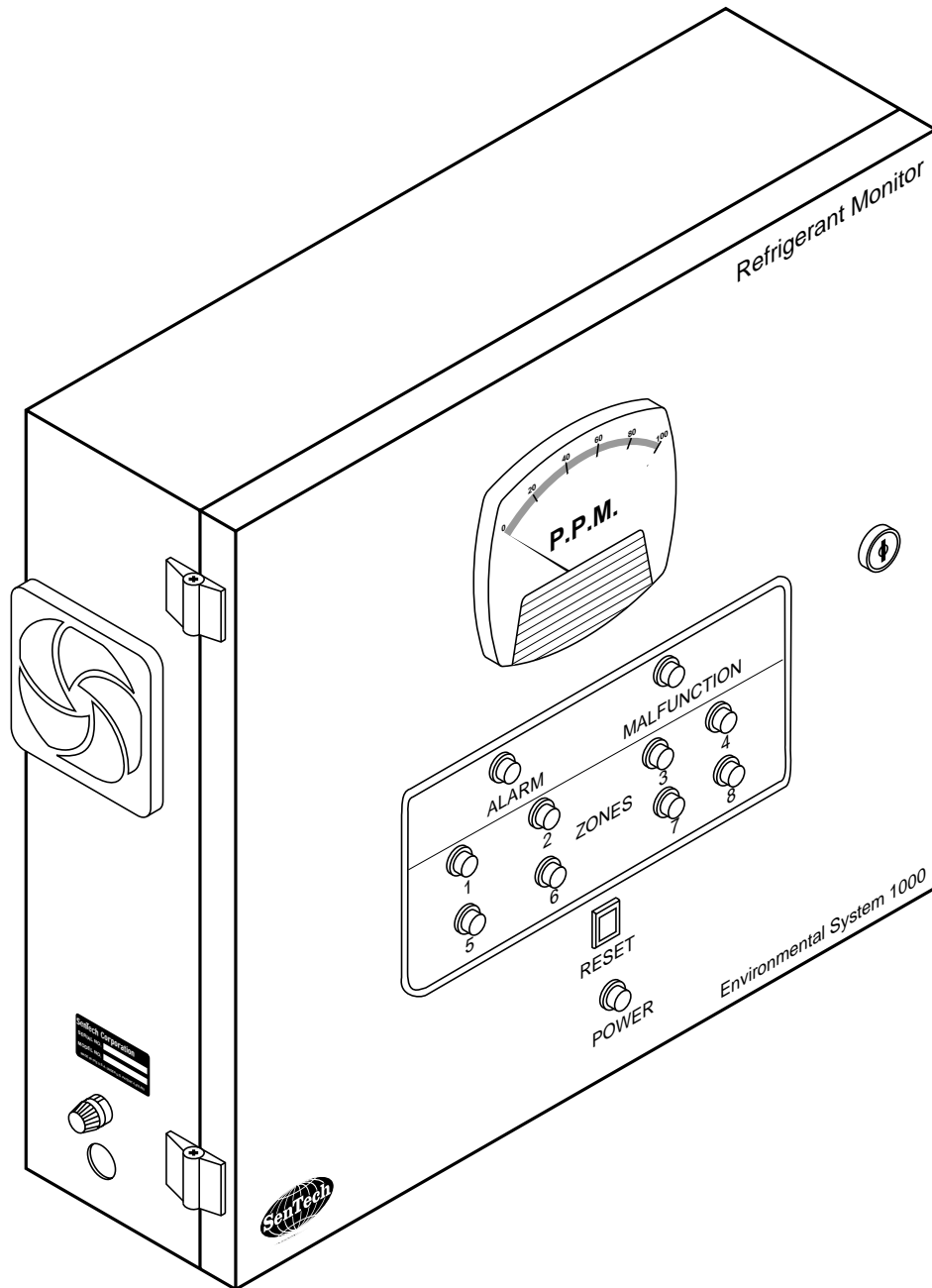

SenTech Corporation
5745 Progress Road
Indianapolis, Indiana 46241
317/248-1988
FAX 317/248-2014

Contents

INTRODUCTION/OVERVIEW	1
Basic Concept	1
Sensitivity	1
INSTALLATION	2
Location	2
Mounting	2
Tubing Installation	2
Zone Selection	2
Primary Power	2
OPTIONAL CONNECTIONS	2
Alarm Relay Contacts	2
Analog Outputs	2
START-UP & OPERATIONS	3
Modes of Operation	3
Controls & Displays	4
START-UP	4
PREVENTIVE MAINTENANCE	5
Air Filters	5
5 Micron Sensor Inlet Filter and Orifice	5
Periodic Performance Check	5
Quarterly Performance Check	5
APPENDIX A	6
Trip Point & Function Switch Settings	6
Trip Point Setting/Calibration	7
APPENDIX B	8
Room Volume Considerations (English)	8
Room Volume Considerations (Metric)	9
EXPLODED VIEW & PARTS LIST	10
WIRING DIAGRAM	11
TROUBLESHOOTING GUIDE	12
WARRANTY	15
PARTS ORDER PROCEDURE	16
ILLUSTRATIONS	
Fig. 1 Block Diagram	1
Fig. 2 Zone Selection	2
Fig. 3 Primary Power Wiring Diagram	2
Fig. 4 Optional Connection Wiring Diagram	3
Fig. 5 Analog Output	3
Fig. 6 Front Panel	4

Model 1204/1208 Specifications	
Size:	16 1/2" X 15" X 6 3/4" (42 cm X 38.1 cm X 17 cm)
Weight:	25 lbs (11.4 kgs)
Power:	120/240 Volt, 50/60 Hz (60 Watt) 100/200 Volt, 50/60 Hz (60 Watt)
Temperature:	32°- 125° Fahrenheit (0°- 50° Centigrade)
Range:	0 - 100 P.P.M. Standard 0 - 1000 P.P.M. for HFC's
Tube Length	0-200 ft. (60 meters)
Zones	Model 1204 - 1 to 4 switch Selectable Model 1208 - 1 to 8 switch selectable
Trip Point:	0 - 100% of FS
Leak Wait:	Varies from seven (7) seconds to three (3) minutes depending on refrigerant concentration
Alarm Output:	Alarm Relay - Four (4) form C contacts rated 5 Amps maximum

INTRODUCTION/OVERVIEW

The SenTech Environmental System 1000, Models 1204 and 1208 provide an early warning of developing refrigerant leaks. The unit sequentially samples the ambient air in each zone and measures the amount of halogen based refrigerant gases in the air sample. When the proportion of halogens present exceeds a trip point, the system goes into Alarm Mode notifying the user. By discovering the existence of a leak before the refrigerant loss has become great enough to be evident from a loss in equipment performance, the potential refrigerant loss is reduced saving money and helping protect the environment.

Basic Concept

Refer to the Block Diagram (Fig. 1). Tubing from each area to be monitored is connected to the inlet manifold assembly. The electronics sequentially energize the solenoid valves for each zone. The diaphragm pump draws air from the selected zone, through the 5 micron filter, the orifice, and flowmeter into the sensor. The air flows across a heating element in the sensor which ionizes any halogen based molecules present. The ionized halogens cause a current to flow which is proportional to the amount of ions present. The microprocessor controlled circuitry measures the current and provides an output reading of the concentration in PPM (Parts per million). More critically, it compares the ppm level to a preset trip point. When the trip point is exceeded, the unit goes into Alarm Mode. In Alarm Mode, the alarm light flashes, the alarm relay is energized, sampling is stopped and the unit remains in the zone.

Sensitivity

The system is sensitive in varying amounts to all of the normal halogen based refrigerants, that is those molecules that contain either fluorine, chlorine, or both. Because of the variation in sensitivity each unit is calibrated at the factory for the specific refrigerants it is to monitor. In the event no refrigerant has been specified, it is calibrated for R-22. When appropriately calibrated, the monitor can sense concentrations as low as 1 PPM (10-20 PPM HFC's).

There is no direct relationship between the amount of refrigerant leaking and the concentration level being measured. The size of the room, the location of the pick up point relative to the leak point, and the air pattern, all will affect the actual concentration at the inlet. However, by judicious location of the inlets (see installation section) and maintaining the trip point at a level not too far above the ambient, leaks should be detected substantially before they otherwise would be noticed.

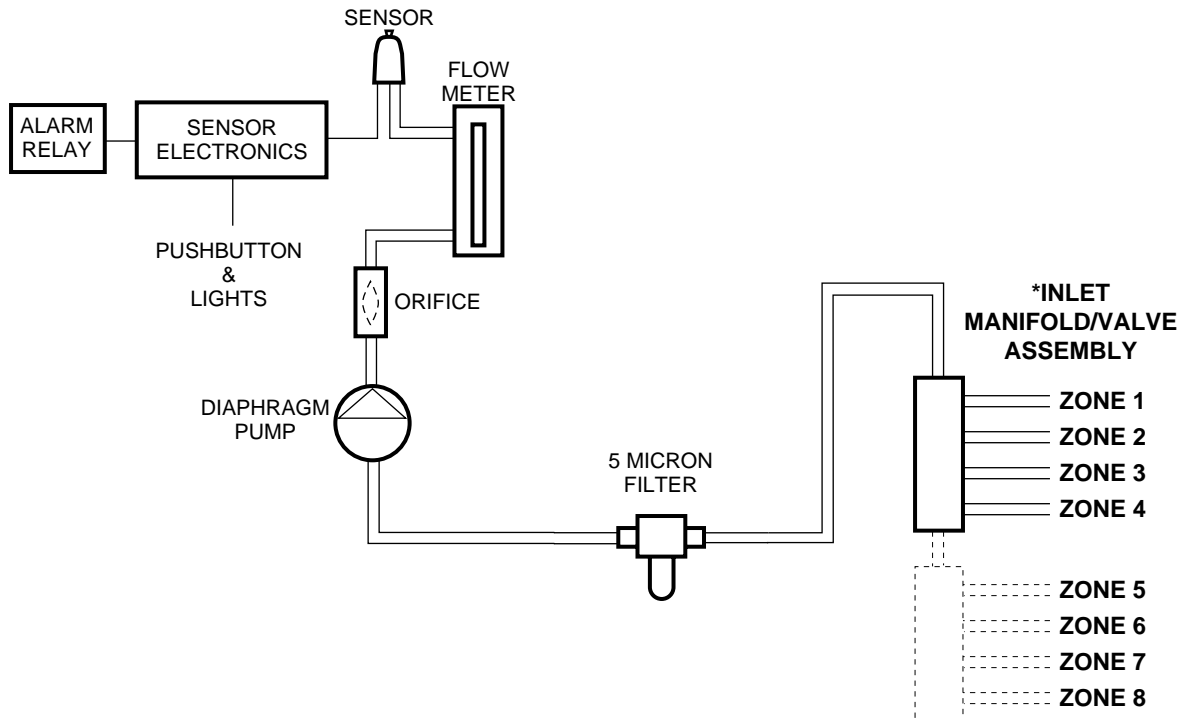

Fig. 1
Model 1204 Block Diagram

INSTALLATION

Location

Since the sensor measures the concentration of refrigerant in air, each zone pick up point should be mounted where it is most likely to sense leaking refrigerant. The criteria to consider in selecting a location include:

1. As close to the area of potential leaks as possible. On the "downstream" side of the air flow pattern in the room.
2. Since refrigerants are typically heavier than air, the pickup tubes should be terminated 20 inches (50 cm) above the floor.
3. The control unit should be located such that the farthest pick up point will require no more than 200 feet (60 meters) of tubing. The monitor includes sensitive electronics and a sensor operating at 900 degrees Celsius, the area should be free from vibration to the extent practical.

CAUTION

MOISTURE CAN DAMAGE THE SENSOR, PICK UP POINTS MUST BE LOCATED AND PROTECTED WHERE NECESSARY TO PREVENT WATER FROM ENTERING THE SYSTEM.

Material Required

Packed with the system

1. The sensor in a plastic tube with desiccant to keep it moisture free during storage and shipment.
2. The coarse tube end filters.
3. The CTS/Warranty card which is to be completed and returned after start-up.

Customer supplied or optionally purchased:

1. Plastic tubing 1/4" OD for the remote pick up points.
2. Horns, lights or other warning devices.

Mounting

Drill the necessary holes and mount the unit. Unpack the sensor and carefully insert the sensor into the socket mounted on the aluminum bracket. Make certain that the sensor is well seated.

Tubing Installation

Install the 1/4" tubing from each zone pickup point to the zone inlet fittings on the right side of the control unit. It is recommended that you start with zone 1 at the top, and continue in sequence until the tube for each zone is installed. Terminate the tubing with the coarse filters.

Zone Selection

The 1200 series monitors allow you to select the number of zones to be monitored. For example, if the system being installed is a Model 1208 and only 6 zones are to be monitored, the two unused zones can be deselected. By deselecting the zones, no time will be wasted monitoring the unused zones. The units are shipped with all zones selected, that is all four zones for the Model 1204 and all eight for the Model 1208.

Zone selection/deselection is accomplished using DIP switch SW3 which is at the upper left hand corner of the control board (see Appendix A). A zone is selected by depressing the appropriate switch so that it is "in" at the bottom. Figure 2 below illustrates Zones 1, 2, and 3 selected.

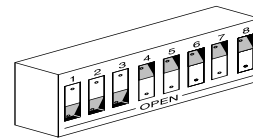
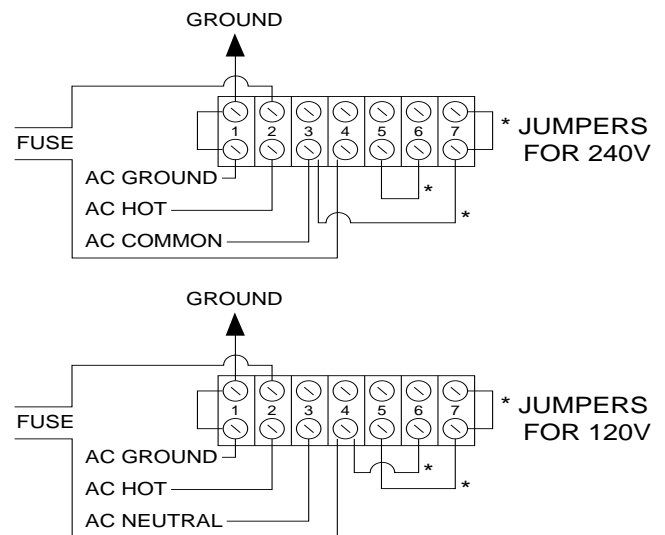

Fig. 2
Zone Selection, DIP Switch SW#3

Primary Power Wiring

Refer to the primary power wiring diagram (Fig. 3). Primary power should be supplied to the unit through the bushing located on the left side of the box. It is strongly recommended that power be supplied from a separate disconnect, NOT by plugging into a wall socket. The unit is a continuous monitor. If a wall socket is used, there is a risk that the unit will inadvertently be unplugged putting it off line.



NOTE: UNITS FOR USE IN JAPAN ARE 100V/200V.

Fig. 3
Primary Power Wiring Diagram

OPTIONAL CONNECTIONS

Alarm Relay Contacts

Using customer supplied power, warning lights and or horns are to be connected in the manner shown (Fig. 3). Use an auxiliary contactor for heavy loads such as exhaust fans. Note: Alarm relay contacts are rated five (5) Amps maximum.

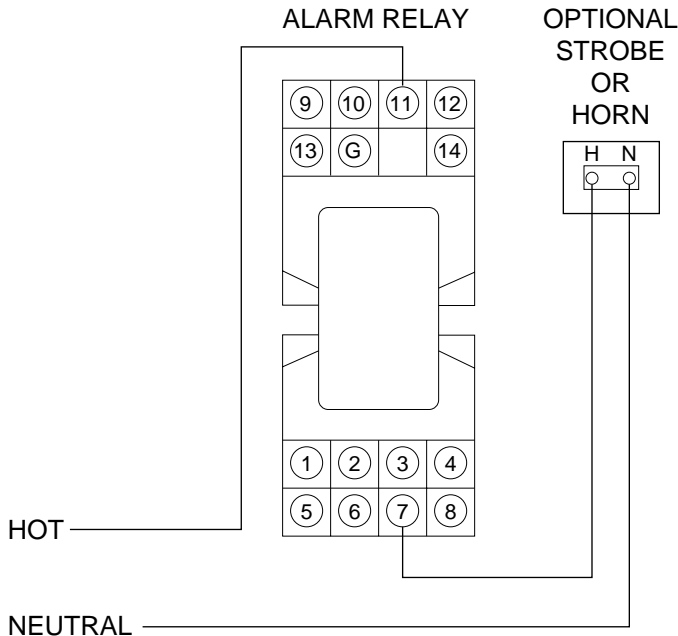

Fig. 4
Option Connection Wiring Diagram

Analog Outputs

For the following discussion, refer to Fig. 5 Analog Outputs

0-5 Volt DC Analog Output

The 0-5 Volt DC analog output is available at TB-2 (Fig. 5). Terminal 6 is the positive side of the output and terminal 7 is the negative side of the output.

4-20MA Output (Optional)

If the 4-20ma option has been purchased, the output is available at terminals 5 and 7 of TB2. Terminal 7 is the common and Terminal 5 is the plus current output.

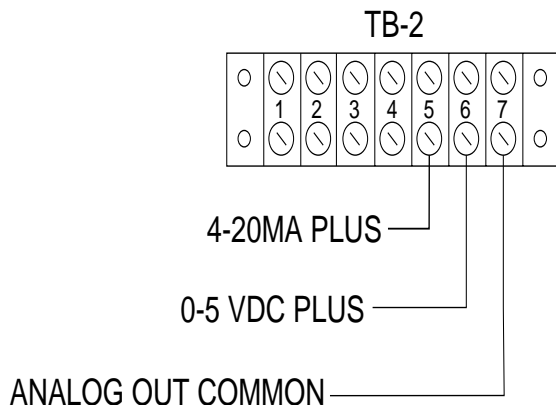

FIGURE 5

After double checking the wiring, turn to the section on Start-up and Operations before applying primary power.

START UP AND OPERATIONS

Before applying primary power to the Model 1204 or 1208, read this section in its entirety.

⚠ WARNING

THE SENSOR OPERATES AT A TEMPERATURE OF 90° CELSIUS (1650° FAHRENHEIT). IF THERE IS ANY REASON TO SUSPECT THE PRESENCE OF A COMBUSTIBLE ATMOSPHERE, THE SYSTEM SHOULD NOT BE TURNED ON UNTIL THAT HAS BEEN ELIMINATED.

Modes of Operation

The Models 1204 and 1208 have 5 modes or states that they can be in. These are:

Warm-up: When power is applied or after an alarm condition has been reset, the system goes through a 3 minute warm-up period, and switches to the lowest selected zone.

Monitoring: After warm-up, the system goes into Monitor Mode. It sequentially samples the air from each zone providing a readout of the refrigerant concentration. The unit spends two minutes in each zone. After completing the last zone, it switches back to the first selected zone and repeats the cycle.

Leak Wait: When the concentration of refrigerant in the ambient air exceeds the preset trip point, the system enters the Leak Wait Mode. During Leak Wait, the system stops scanning and remains in the zone until an Alarm occurs or the concentration falls below the trip point. The system stays in leak wait for a period of time ranging from 7 seconds to 3 minutes. The larger the PPM reading the shorter the wait period. The purpose of the wait is to avoid going into alarm for a brief transient increase in halogen background. During Leak Wait the PPM meter oscillates between 0 and the PPM reading.

Alarm: After the leak wait timing is complete, the system enters Alarm Mode. The Alarm Relay is energized, the Alarm Light flashes once per second, the meter continues to display the PPM reading, and the unit remains in the zone. The system remains in Alarm Mode until there is a reset.

The Alarm Light and Relay are also actuated if a Malfunction occurs (see below). During the Malfunction Alarm, the Main Alarm Light flashes at a rate of twice per second.

Malfunction: The Models 1204 and 1208 monitor the sensor system, and should a failure occur, the system enters Malfunction Mode. The Malfunction Light and the Main Alarm Relay are energized. The Main Alarm Light flashes at a rate of twice per second.

Test: Test Mode is selected by one of the DIP switch positions in the monitor (see Appendix A). In Test, the Alarm light is lit continuously and the unit remains in the current zone. If the maintenance work is to be done on a different zone, use DIP switch SW3 to select the desired zone. The test mode bypasses all other modes and it is for maintenance purposes only.

⚠ WARNING

IF THE ZONE SELECTION SETUP HAS BEEN CHANGED DURING TEST, BE CERTAIN TO RETURN TO THE DESIRED OPERATIONAL SETUP BEFORE GOING BACK TO NORMAL OPERATION.

NEVER LEAVE THE SYSTEM IN TEST MODE SINCE IT WILL NOT ALARM IN THE PRESENCE OF A LEAK.

Controls and Displays

The front panel contains the output meter, display lights and a reset push-button (Fig. 6).

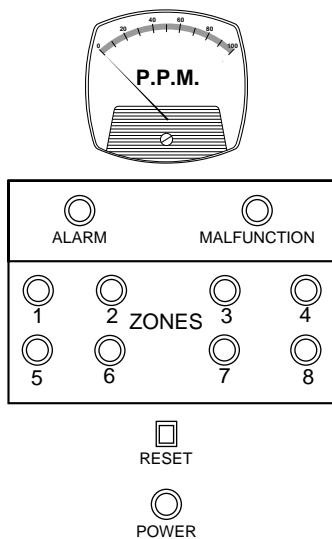

Fig. 6
Front Panel

Power Light: A green light indicating that power is applied to the monitor.

Alarm Light: The alarm light has several functions. When power is first applied, or when the unit is reset, the light flashes three (3) times indicating the start of the warm-up period. In Alarm Mode, the light flashes once per second and continues to flash until there is a reset. In Malfunction, the Alarm Light flashes twice per second and continues to flash until there is a reset. In Test Mode, the Alarm light

is on continuously, warning that the unit is in Test Mode.

Malfunction Light: The Malfunction Light is energized when the system detects a malfunction.

Zone Lights: The zone lights indicate which zone is active.

Reset Push Button: The reset push-button resets the unit from an alarm condition. If the ambient level of refrigerant still exceeds the trip point the unit will go back into an alarm condition after warm-up and leak wait.

PPM Meter: The PPM meter provides a display of ambient refrigerant levels in parts per million during the normal or monitoring mode. In Start-up Mode, the meter reads 0 ppm. During leak wait, the meter oscillates between 0 and the refrigerant level present, providing an indication that the unit is in Leak Wait mode. In Alarm Mode, the meter continues to display the actual level of refrigerant present. In Test Mode the meter displays the ambient refrigerant level.

START-UP

Step 1: Having confirmed that the wiring is correct, apply power to the unit. The warm-up period is 3 minutes. However, power has been off since the unit was tested at the factory, allow the unit to warm-up for a minimum of 30 minutes (6-8 hours is preferable).

⚠ WARNING

THE SENSOR OPERATES AT 900° CELSIUS, 1650° FAHRENHEIT, AND 180 VOLTS. NEVER TOUCH THE SENSOR WHILE POWER IS APPLIED.

Step 2: Allow the unit to sequence through all the selected zones. Make certain that every desired zone is selected, and that there are no unnecessary zones active.

Check the flowmeter reading in each zone to make certain that there are no kinks or blockages in the tube runs.

Check the PPM meter reading in each zone. The meter should read less than 5. If the unit is reading 10 or higher or, has gone into the Leak Wait Mode or Alarm Mode, in any zone, it is likely that there is a leak present. A high reading may also result from the recent use of a chlorinated cleaning agent. Many industrial degreasers do use a chlorine based compound. Examples are trichloroethylene and perchloroethylene based solvents or cleaners. If you are convinced that there is no leak, and that there are no other sources of halogen vapors in the room, contact SenTech.

Step 3: The trip point setting of the unit is written on the inside front cover. Make note of the setting.

Step 4: To check for proper operation of the Monitoring, Leak Wait, and Alarm modes, it is necessary to prepare a

sample of the refrigerant gas being used.

CAUTION

VERY HIGH CONCENTRATIONS OF REFRIGERANT CAN SIGNIFICANTLY SHORTEN SENSOR LIFE. NEVER SQUIRT PURE REFRIGERANT TOWARDS THE SENSOR OPENING.

a) Gaseous refrigerants: Obtain a small plastic garbage bag (waste basket size is fine). Open the bag and “fluff” it so that it is full of air. Insert a refrigerant fill hose into the bag opening. Close the mouth of the bag around the hose. Crack the valve for a second or less so that a small squirt of refrigerant enters the bag. Keep in mind the monitor reads in parts per million and a tiny amount of gas will make a relatively high concentration sample. Pull out the hose, and hold the bag tightly closed.

b) Liquid refrigerants: Obtain a small plastic “Ziplock[®]” type food storage bag. Open the bag slightly and put in a few drops of liquid refrigerant. Flatten the bag so that there is little air and seal it as tightly as possible. Warm the bag to gasify the refrigerant. The bag will expand as the liquid evaporates, but the seal should be good enough to keep any gas from escaping.

Step 5: Test to see that Leak Wait and Alarm Mode are operating properly. We are going to use the refrigerant sample to simulate a concentration of refrigerant in the air that is reasonably higher than the trip point. **NOTE: THE MORE THE READING EXCEEDS THE TRIP POINT THE SHORTER LEAK WAIT TIME.**

Disconnect the plastic tube from the active zone.

a) Gaseous refrigerants: Holding the bag tightly closed, bring the bag to just under the active inlet. Carefully loosen your grip on the bag to allow some gas to escape, watching the meter as you do this. You should try and allow enough gas to leak to cause the meter to rise to 60 to 90 PPM. Precision is not possible, and the goal is to see the unit enter Leak Wait Mode and then Alarm Mode

b) Liquid refrigerants: Using a pin or paper clip, prick a hole in the bag. Hold the bag just under the active inlet. Squeeze the bag slightly and watch the meter. You should try and allow enough gas to leak to cause the meter to rise to 60 to 90 ppm. Precision is not possible, and the goal is to see the unit enter Leak Wait Mode and then Alarm Mode.

In either a) or b), there will be a five (5) second delay before the meter starts to react.

Step 6: The system should now be in Alarm Mode. Confirm that the alarm light is flashing. Check that any optional horns, lights, or other devices are appropriately energized.

Step 7: Push reset to put the system back into Monitor Mode, and reconnect the pickup tube.

Step 8: Dispose of the gas samples in an appropriate manner.

Step 9: Fill out the CTS/Warranty card completely and return to SenTech. This is an important step and must not be overlooked.

Step 10: Store this manual in safe place so that it will be available for future reference.

Basic installation and start-up are now complete, and the unit is on line and monitoring.

PREVENTIVE MAINTENANCE

Air Filter: The only preventive maintenance that needs to be accomplished on a routine basis is to periodically clean or replace the cooling air inlet filter. A dirty filter will reduce cooling air flow and could shorten the life of the electronics. The cooling air filter should be cleaned at least once per quarter.

5 Micron Sensor Inlet Filter and Orifice: At least once per quarter, compare the flowmeter reading to the initial flow noted on the decal on the inside of the door. If the flow has dropped by 100 cc/s/min or more, either the orifice or the 5 micron filter or both have become partially blocked.

Periodic Performance Check: Once a week, push the reset pushbutton and check that the analog reading goes to zero and the system goes through the normal warmup procedure. After the unit is back on line, check that ambient PPM reading is in the normal range for your environment.

Quarterly Performance Check: Once per quarter, go through steps 4 through 8 of the start up instructions.

APPENDIX A TRIP POINT AND FUNCTION SWITCH SETTINGS

There are three 8-position dip (dual in-line package) switches on the main control board, see Appendix Diagram "A". Switch S1 is a function switch. Switch S2 is used to set the trip point for Alarm Mode. Switch S3 is the zone selection switch.

S1 Function Switch

Positions 1 through 7:

These positions are used to set parameters for communicating to external devices and computers. If you have one of these options, refer to the instruction literature provided with the option for information on how to set the switches. If you are not using the external communications capabilities, you can ignore positions 1 to 7. They do not affect any other function.

Position 8 Run/Test:

Position 8 determines whether the unit is in Run Mode or Test Mode. Test mode is used for trouble shooting and maintenance. For normal operation the position 8 must be in Run mode. Appendix Diagram "A" shows the switch in the run position. In the Test Mode, the Alarm Light is on continuously.

S2 Trip Point

Switch 2 is used to set the trip Point, the PPM reading at which the unit will go into Alarm Mode. See the following page, Trip Point Settings displays how to set the switch for a variety of refrigerant levels. The switch has been preset at the factory. There is a label on the inside front cover of the unit with the value of the preset trip point. If the switch setting is changed, note this change on the label inside the front panel of the unit to indicate the new trip point, when it was set, and who set it. This can be a big help in troubleshooting should a problem develop.

The switch essentially provides the computer with an 8 bit binary fraction of the full scale of the unit. For example if full scale of the monitor is 100 PPM, setting position 8 will be a trip point of 50 or half of full scale. Position 7 is one fourth of full scale, and so on down to position 1 which is one two hundred and fifty-fifth of full scale. By combining switches, it is possible to get any trip point required. For ease of use, it is suggested that you use the chart provided.

S3 Zone Selection

S3 allows you to select the active zones. A zone is selected by depressing the switch for that zone. The illustration shows zones 1, 2, and 3 selected. The unit will start testing zone 1 than switch to zones 2 then 3 and then back to zone 1. Be careful not to select more zones than you need., and for four zone models be sure not to select any of the higher zones (5-8).

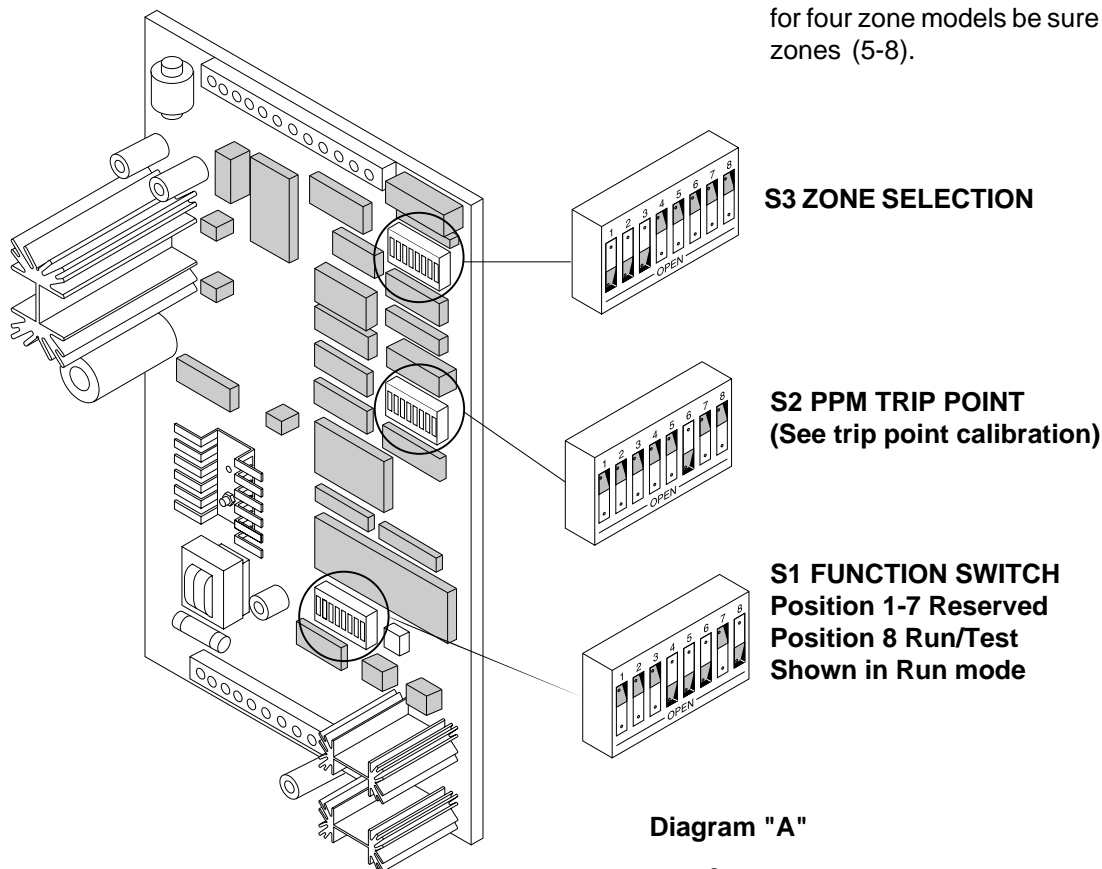

TRIP POINT SETTINGS 100 PPM FULL SCALE CALIBRATION

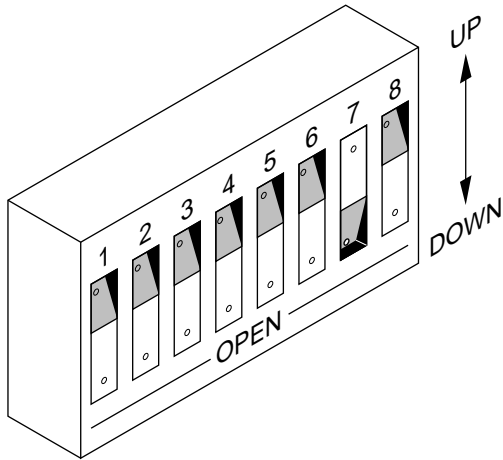

FIGURE 1
TRIP POINT SETTING
@ PPM - 25
(DIP SWITCH - 7)

PPM	DIP SWITCH DOWN
*0	NONE
5	1,3,4
6.75	5
10	1,4,5
12.5	6
15	2,3,6
20	1,2,5,6
25	7
30	1,3,4,7
35	1,4,5,7
40	2,3,6,7
45	1,2,5,6,7
50	8
60	1,4,5,8
70	1,2,5,6,8
80	3,4,7,8
90	2,3,6,7,8
*100	1,2,3,4,5,6,7,8

Not recommended
unless normal
ambient very high

*** DO NOT USE**

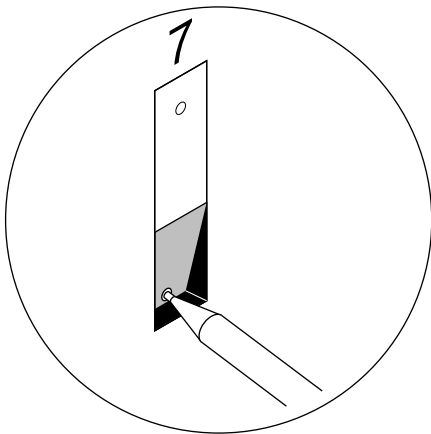

FIGURE 2
USE A PENCIL OR FINE TIP PEN
TO SET THE SWITCHES
(ILLUSTRATION SHOWS SWITCH #7 DOWN)

NOTE:

For units with 0-1000 PPM full scale,
multiply the PPM reading by 10.

Examples

<u>PPM</u>	<u>Dip Switch Down</u>
125	6
200	1,2,5,6
250	7

Appendix B: SenTech Room Volume Considerations (English)

Normal industry practice is to think about refrigerant leaks in terms of pounds of refrigerant per unit time such as lbs/hr or ozs/yr. This is a natural and logical way of looking at it. The system monitors the amount of refrigerant present in the air in Parts Per Million (ppm) by volume of refrigerant molecules as compared to air molecules. In order to develop a relationship between the leak rate in weight per unit time and ppm reading of the monitor, there are a number of items that need to be considered and accounted for. These are:

1. Room Volume.
2. The relationship between refrigerant amount in weight compared to refrigerant volume at the temperature and pressure of the room.
3. The amount of time the refrigerant has been leaking.
4. The rate at which fresh air enters the room (stale air is exhausted).
5. The location of the monitor inlet relative to the leak, the air patterns of the room, and the rate at which the leaking refrigerant expands to fill the room.

For a given specific situation items 1 through 4 are either known, can be calculated, or can be estimated. Item 5 is virtually unknowable, therefore in all the formulas and sample calculations it is assumed that leaking refrigerant expands immediately to fill the room. This is a reasonable and conservative assumption on the basis that you have located the monitor following the recommendations outlined in the installation section. If you have followed those recommendations, the monitor should see a higher concentration sooner than the idealized formulas.

The equations have been developed for two cases. **Case I** is for a sealed room, no air turnover. **Case II** is for a room with a known turnover of air.

To be able to convert between a leak rate in cubic feet per hour to a leak rate in pounds per hour the molecular weight of the refrigerant needs to be known. If you know the molecular weight of the refrigerant, you can calculate the necessary conversion factors at normal atmospheric pressure and room temperature.

$$\frac{\text{Mol Wt(gms)}}{1(\text{mole})} \times \frac{1(\text{mole})}{22.4(\text{ltrs})} \times \frac{1(\text{pound})}{454(\text{gms})} \times \frac{28.32(\text{ltrs})}{1(\text{cuft})} \times \frac{273}{293} = \frac{\#}{\text{cuft}}$$

Substituting for R-22 which is 86.48 grams/mole, you get $0.22 \frac{\#}{\text{cuft}}$.

Conversion Factors for Common Refrigerants

R-22	.22 #/cuft	4.46 cuft/#
R-12	.31 #/cuft	3.18 cuft/#
R-11	.36 #/cuft	2.80 cuft/#
R-502	.29 #/cuft	3.45 cuft/#
R-123	.41 #/cuft	2.41 cuft/#

PPM READINGS AND LEAK RATE RELATIONSHIP DEFINITIONS:

- PPM = Monitor PPM reading or trip point PPM setting
- LR = Leak Rate of refrigerant in cubic feet per hour
- FA = Fresh Air into the room in cubic feet per hour
- VOL = Volume of the room in cubic feet
- t = Time in hours (There are 8760 hours in one year)
- R = Amount of refrigerant in the room in cubic feet
- LR_{min} = Minimum leak rate that will reach a given PPM

Case I: Sealed Room

$$\text{PPM} = \frac{\text{LR} \times t \times 10^6}{\text{VOL}} \quad t = \frac{\text{PPM} \times \text{VOL} \times 10^{-6}}{\text{LR}}$$

$$R = \text{PPM} \times \text{VOL} \times 10^{-6}$$

Case II: Room with Air Changing

$$\text{PPM} = \frac{\text{LR}}{\text{FA}} \left(1 - e^{-\frac{\text{FA}}{\text{VOL}}t}\right) 10^6$$

$$t = \frac{\text{VOL}}{\text{FA}} \times \ln \left(\frac{\text{LR}}{\text{LR} - \text{PPM} \times \text{FA} \times 10^{-6}}\right)$$

$$\text{LR}_{\text{min}} = \text{PPM} \times \text{FA} \times 10^{-6}$$

Sample Calculations (Assuming The room is 40 feet by 30 BY 10 feet = 12,000 cuft)

Case I: Sealed Room

1. How much refrigerant is necessary to cause a 25 ppm reading ?
 $R = 25 \times 12000 \times 10^{-6} = .3 \text{ cuft}$
 If it is R-22: $.3 \text{ cuft} \times .22 \text{ lb/cuft} = .066 \text{ lbs}$
2. If the leak rate is 300 lbs./year of R-22, how long will it take to reach 25 ppm ?

$$\frac{300 \text{ lbs}}{\text{yr}} \times \frac{1 \text{ yr}}{8760 \text{ hr}} \times \frac{4.46 \text{ cuft}}{\text{lbs}} = .153 \text{ cuft/hr}$$

$$t = \frac{25 \times 12000 \times 10^{-6}}{.153} = 1.96 \text{ hrs}$$

Case II: Room with Air Changing

Assume the same room 12,000 cuft.
 Assume fresh air at 100 cfm or 6000 cuft/hr (1 air changes in 2 hour).

1. What is the minimum leak that will reach 25 ppm ?
 $\text{LR}_{\text{min}} = 25 \times 6000 \times 10^{-6} = .15 \text{ cuft/hr}$
 for R-22: $.15 \text{ cuft/hr} \times .22 \text{ lb./cuft} = .033 \text{ lbs/hr}$ or 289 lbs/yr

2. How long will it take to detect a leak of 500 lbs/yr of R-22?
 $500 \text{ lbs/yr} = .26 \text{ cuft/hr}$
 $t = \frac{12000}{6000} \times \ln \left(\frac{.26}{.26 - 25 \times 6000 \times 10^{-6}}\right) = 1.72 \text{ hrs}$

3. If the trip point is set at 10 ppm, what is the minimum leak rate of R-123 that will trigger the alarm ?

$$\text{LR}_{\text{min}} = 10 \times 6000 \times 10^{-6} = .06 \text{ cuft/hr}$$

for R-123: $.06 \times .41 \text{ lbs/ft} = .0246 \text{ lbs/hr}$ or 215 lbs/yr

4. How long will it take to detect a leak of 300 lbs/yr of R-123 ?
 $300 \text{ lbs/yr of R-123} = .0825 \text{ cuft/hr}$

$$t = \frac{12000}{6000} \times \ln \left(\frac{.0825}{.0825 - 10 \times 6000 \times 10^{-6}}\right) = 2.6 \text{ hrs}$$

These numbers represent worst case conditions. With the monitor placed close to the potential leak points and on the "downwind" side of the air flow, the trip points are likely to be activated sooner.

Appendix B: SenTech Room Volume Considerations (Metric)

Normal industry practice is to think about refrigerant leaks in terms of weight of refrigerant per unit time such as kg/hr or kg/yr. This is a natural and logical way of looking at it. The system monitors the amount of refrigerant present in the air in Parts Per Million (ppm) by volume of refrigerant per volume of air. In order to develop a relationship between the leak rate in weight per unit time and ppm reading of the monitor, there are a number of items that need to be considered and accounted for. These are:

1. Molecular weight of the refrigerant.
2. Density of the refrigerant at the temperature of the room.
3. Room volume.
4. The rate at which fresh air enters the room.
5. The location of the monitor inlet relative to the leak, the air patterns of the room, and the rate at which the leaking refrigerant expands to fill the room.

For a given specific situation items 1 through 4 are either known, or can be calculated. Item 5 is virtually unknowable, therefore in all the formulas and sample calculations it is assumed that leaking refrigerant expands immediately to fill the room. This is a reasonable and conservative assumption on the basis that you have located the monitor following the recommendations outlined in the installation section. If you have followed those recommendations, the monitor should see a higher concentration sooner than the idealized formulas.

The equations have been developed for two cases. **Case I** is for a sealed room, no air turnover. **Case II** is for a room with a known turnover of air.

To be able to convert between a leak rate in cubic meters per hour to a leak rate in kilograms per hour the density of the refrigerant must be known. At normal atmospheric pressure and room temperature.

$$\text{DENSITY (kg/m}^3\text{)} = \frac{\text{Mol Wt(gms)}}{22.4(\text{ltrs})} \times \frac{273}{293} \times \frac{1(\text{kg})}{1000(\text{gms})} \times \frac{1000(\text{ltrs})}{1(\text{m}^3)}$$

As an example for R-22, Mol Wt = 86.48 gm/mole.
Therefore density = 3.59 kg/m³, or 0.28 m³/kg

Conversion Factors for Common Refrigerants

R-22	3.59 kg/m ³	0.28 m ³ /kg
R-12	4.96 kg/m ³	0.20 m ³ /kg
R-11	5.76 kg/m ³	0.17 m ³ /kg
R-502	4.64 kg/m ³	0.21 m ³ /kg
R-123	6.56 kg/m ³	0.15 m ³ /kg

PPM READINGS AND LEAK RATE RELATIONSHIP DEFINITIONS:

- PPM = Monitor PPM reading or trip point PPM setting
- LR = Leak Rate of refrigerant in cubic meter per hour
- FA = Fresh Air into the room in cubic meter per hour
- VOL = Volume of the room in cubic meter
- t = Time in hours (There are 8760 hours in one year)
- R = Amount of refrigerant in the room in cubic meters
- LR_{min} = Minimum leak rate that will reach a given PPM

Case I: Sealed Room

$$\text{PPM} = \frac{\text{LR} \times t \times 10^6}{\text{VOL}} \quad t = \frac{\text{PPM} \times \text{VOL} \times 10^{-6}}{\text{LR}}$$

$$R = \text{PPM} \times \text{VOL} \times 10^{-6}$$

Case II: Room with Air Changing

$$\text{PPM} = \frac{\text{LR}}{\text{FA}} (1 - e^{-\frac{\text{FA}}{\text{VOL} \cdot t}}) 10^6$$

$$t = \frac{\text{VOL}}{\text{FA}} \times \ln \left(\frac{\text{LR}}{\text{LR} - \text{PPM} \times \text{FA} \times 10^{-6}} \right)$$

$$\text{LR}_{\min} = \text{PPM} \times \text{FA} \times 10^{-6}$$

SAMPLE CALCULATIONS (ASSUMING THE ROOM IS 15 METERS BY 10 METERS BY 3 METERS = 450 CUBIC METERS)

Case I: Sealed Room

1. How much refrigerant is necessary to cause a 25 ppm reading ?
R = 25 x 450 x 10 = .0011 cubic meter
If it is R-22:
Amount of refrigerant = .0011 m³ x 3.59 kg/m³ = .004 kg
2. If the leak rate is 150 kg/year of R-22, how long will it take to reach 25 ppm ?
$$\frac{150 \text{ kg}}{\text{yr}} \times \frac{1 \text{ yr}}{8760 \text{ hr}} \times \frac{.28 \text{ m}^3}{\text{kg}} = 0.0048 \text{ m}^3/\text{hr}$$

$$t = \frac{25 \times 450 \times 10}{0.0048} = 2.35 \text{ hrs}$$

Case II: Room with Air Changing

- Assume the same room (450 m³).
Assume fresh air at 225 m³/hr (1 air changes in 2 hour).
1. What is the minimum leak that will reach 25 ppm ?
LR_{min} = 25 x 225 x 10 = 0.0056 m³/hr
for R-22:
0.0056 m³/hr x 3.59 kg/m³ = 0.02 kg/hr OR 175 kg/yr
 2. How long will it take to detect a leak of 200 kg/yr of R-22?
200 kg/yr = 0.023 kg/hr
$$t = \frac{450}{225} \times \ln \left(\frac{.023}{.023 - 25 \times 225 \times 10^6} \right) = 4.0 \text{ hrs}$$
 3. If the trip point is set at 10 ppm, what is the minimum leak rate of R-123 that will trigger the alarm ?
LR_{min} = 10 x 225 x 10 = .00225 m³/hr
for R-123: .00225 x 6.56 kg/m³ = .0148 kg/hr OR 130 kg/yr
 4. How long will it take to detect a leak of 150 kg/yr of R-123 ?
150 kg/yr of R-123 = .0026 m³/hr
$$t = \frac{450}{225} \times \ln \left(\frac{.0026}{.0026 - 10 \times 225 \times 10^{-6}} \right) = 4.0 \text{ hrs}$$

These numbers represent worst case conditions. With the monitor placed close to the potential leak points and on the "downwind" side of the air flow, the trip points are likely to be activated sooner.

MODEL 1208, EXPLODED VIEW

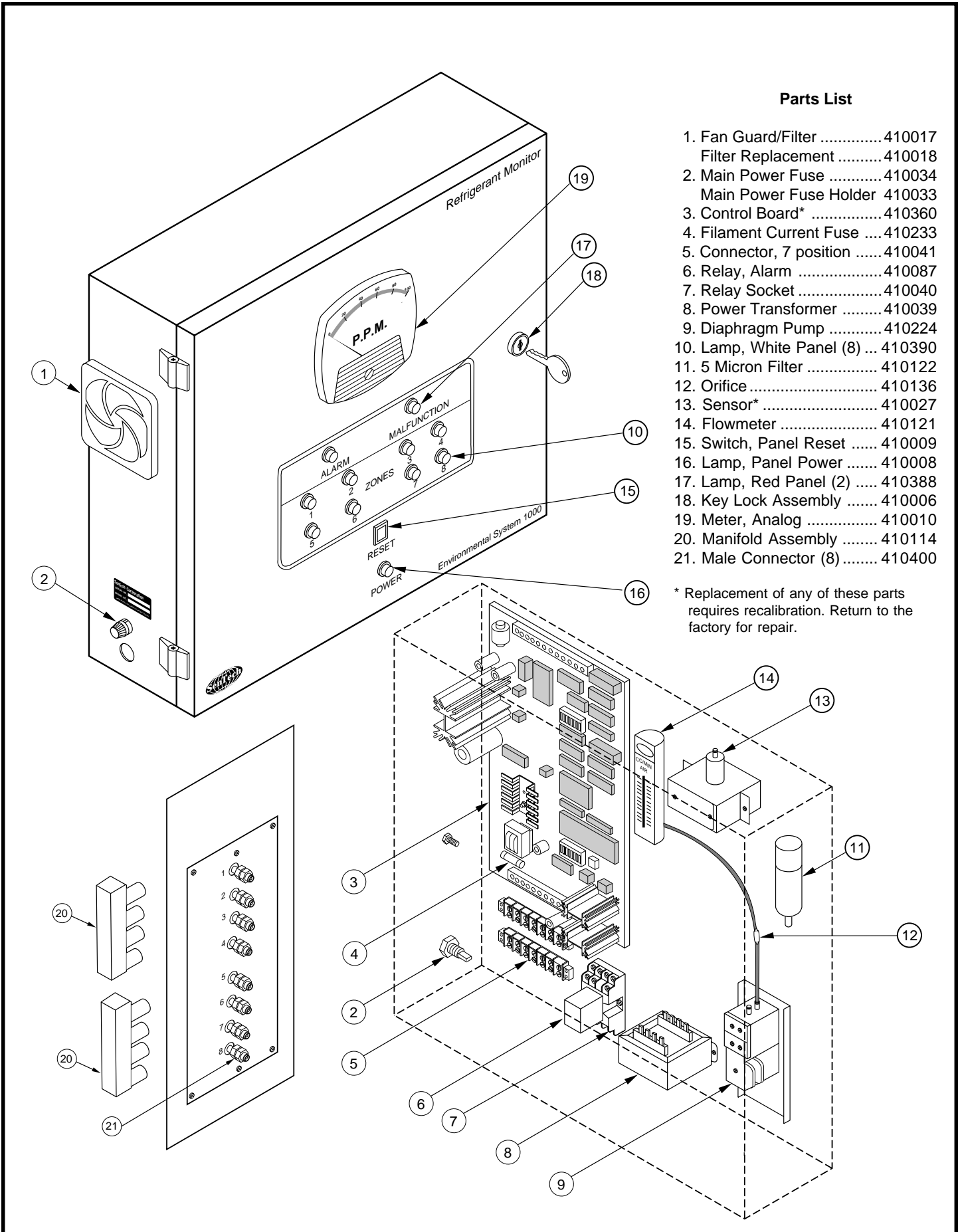

Parts List

- 1. Fan Guard/Filter 410017
- Filter Replacement 410018
- 2. Main Power Fuse 410034
- Main Power Fuse Holder 410033
- 3. Control Board* 410360
- 4. Filament Current Fuse 410233
- 5. Connector, 7 position 410041
- 6. Relay, Alarm 410087
- 7. Relay Socket 410040
- 8. Power Transformer 410039
- 9. Diaphragm Pump 410224
- 10. Lamp, White Panel (8) ... 410390
- 11. 5 Micron Filter 410122
- 12. Orifice 410136
- 13. Sensor* 410027
- 14. Flowmeter 410121
- 15. Switch, Panel Reset 410009
- 16. Lamp, Panel Power 410008
- 17. Lamp, Red Panel (2) 410388
- 18. Key Lock Assembly 410006
- 19. Meter, Analog 410010
- 20. Manifold Assembly 410114
- 21. Male Connector (8) 410400

* Replacement of any of these parts requires recalibration. Return to the factory for repair.

Troubleshooting Guide

Before starting, refamiliarize yourself with the START-UP section of the manual. Depending on the problem, you may need to prepare a sample of refrigerant to use in testing. You should also check the appendix on setting the trip point and function switches. Certain of these tests will require the use of a volt/ohm multimeter.

If you determine that there is a problem in the the control board, the unit will have to be returned to the factory for repair and recalibration. A sensor may be replaced in the field but there will be a reduction in the calibration accuracy

Symptom	Remedy
1. No power light.	<ol style="list-style-type: none">1. Check fuse f1 and replace if failed.2. Check incoming AC Power at TB1-2 and TB1-3 120 (240) Volts AC.
2. Flowmeter reading 0 cc/min.	<ol style="list-style-type: none">1. Check that the diaphragm pump is operating and replace if it has failed.2. Check the tubing from the diaphragm pump output to the flowmeter and make certain that it has not come loose at any point.3. If the tubing run seems continuous with no obvious blockages or kinks, follow the trouble shooting procedures for low flow.
3. Flowmeter reading less than the initial reading by more than 100 cc/min.	<ol style="list-style-type: none">1. Either the orifice or the 5 micron filter or both have become partially or completely blocked or there is a blockage in the tube run for the active zone.<ol style="list-style-type: none">a). Cycle through the active zones (DIP SW3). If the flow is normal, except in one or more zones, check for blockages in the low flow zone. If the flow is low in all zones, go to b). Be sure to reselect all required zones on SW3.b). Unscrew the plastic bottle on the 5 micron filter and recheck the flow. If the flow has returned to normal, replace the 5 micron filter element.c). If the flow remains low, remove the orifice and clean it by blowing compressed air through it. Recheck the flow. If it is not back to normal, replace the orifice. Note, the orifice must be replaced with the arrow pointing towards the flowmeter.
4. Failure to detect a leak/suspected low sensitivity.	<ol style="list-style-type: none">1. Alarm light is on continuously, alarm relay did not energize. The system is in test mode, see Appendix A. Set function switch S1 to RUN and push the reset button to go back into normal operation.2. Alarm light is flashing indicating an alarm, but external alarm devices (horns, lights, etc) not actuated.<ol style="list-style-type: none">a). Check for 24 volts DC at the alarm relay coil between p13 and p14. If there is no voltage, the control board has failed*.b). If voltage is present, check that the relay is energized by testing for continuity at an unused set of normally open contacts (see diagram on the inside front cover of the enclosure). If the relay is not energized, replace it.c). If the relay is energized, check the wiring to the external devices, and check the devices themselves for proper operation.3. Check the trip point setting of the unit to make certain that it has not been set too high. Typical trip point settings should be 30 PPM or less. (see Appendix A). If the trip point is too high, reset it and repeat steps 3 through 6 of the start-up procedure to confirm proper operation.4. If steps 1 through 3 have not uncovered the problem, repeat steps 3 through 6 of the start-up procedure. If the system does not respond properly, there has been a failure in the main control board* or sensor.

***A failure in the control board requires the unit be returned to the factory for repair and recalibration.**

Symptom

Remedy

5. System has gone into alarm and it is believed there is no leak, Malfunction light is NOT lit.

5. If all of the checks indicate the unit is operating properly, yet it still believed that a leak was not detected by the system. Review the Location section of the installation procedure. It may be that the pick up point for that zone is not located in an appropriate position.

1. Depress the reset switch, and wait for completion of the warm-up period. Allow the unit to cycle through all zones. If the system does not go into alarm, repeat steps 3 through 6 of the start-up procedure. If the unit appears to operate normally, there may have been a transient phenomenon that caused the alarm. Some examples are:

a). Someone using a halogen based degreaser such as trichloroethylene near the system.

b). A leaky purge that caused a transient increase in the refrigerant level.

Monitor the system closely for the next several weeks to see if it continues to operate normally.

2. If after going through the warm-up cycle, the system goes into alarm yet the meter reading indicates a very low PPM. Check that the trip point setting has not been changed to 0 PPM or a very low value that is likely to be below ambient conditions (see Appendix A). If that is the case, reset the trip point to the appropriate value for your environment, and recheck as in step 1 above.

3. If after going through the warm-up cycle, the system goes into alarm and the meter reading is above the trip point, set function switch S1 in the test mode (see appendix A), and reset the system. In test mode, the alarm circuitry is bypassed and the unit continuously reads ambient PPM level.

Check that the RUN/CAL switch, on the control board, is in the RUN position to the right. If it is in the CAL position, switch to RUN and wait several minutes to see if the PPM decreases to a normal reading. If it is in the RUN position, flip the switch back and forth several times to make certain there is not a contact problem. Leave it in the RUN position, and again wait several minutes to see if the system returns to a normal reading. If the system appears to be working, put the function switch S1 back into the run mode, and press the reset push-button. After the warm-up period, go through steps 3 to 6 of the setup procedure to confirm normal operation.

4. If the RUN/CAL switch test does not resolve the problem, there are three likely possibilities:

a). There is in fact a leak in the refrigerant system.

b). There is a high ambient level of a halogen based hydrocarbon. This may be the result of chemicals stored in the room (such as a leaking refrigerant cylinder).

c). The unit has failed.

There is one inconvenient but sure way of testing for system failure. Disconnect the unit and move it to another area of the building or take it outdoors and supply power to the unit. If you still have a high reading, it is likely there has been a failure in the control board* or sensor.

Symptom

Remedy

6. The Malfunction light is lit.

The malfunction circuitry checks that the sensor is detecting at least a minimal background level.

1. Sensor filament circuit check. Reset the system and using function switch S1, put the unit back in Test Mode. Wait a few minutes, then feel the top of the System 1000 enclosure (just above the sensor area). If it feels warm to the touch, it indicates the sensor is getting current. A double check is to touch the large heatsink at the upper left hand side of the control board. It also should be warm to the touch. If the sensor is warm, go to item 2. If the sensor is not getting current:
 - a). Check the fuse on lower left hand of the control board. If the fuse is blown, replace it with a 7 amp 250 volt slo blo.
 - b). Check that the sensor tube is well seated in the socket.
 - c). Check and tighten the connections at pins 2, 3, and 4 of J2, the connector at the top of the main control board.
 - d). Check for 10 volts AC between J1-1 and J1-2 the connector at the bottom of the main control board. If there is no voltage, or it is substantially below 10 volts, replace the main transformer.
2. Using function switch S1, put the unit in Run Mode (See Appendix A). Push the reset button and wait 3 minutes for the warm up period to end.
 - a). If the unit does not reenter Malfunction Mode, there may have been a transient phenomena that caused the Malfunction to actuate. Repeat steps 3 to 6 of the Start-up procedure to confirm normal operation.
 - b). If after warm up, the Malfunction light comes back on, the control board* or sensor has failed.

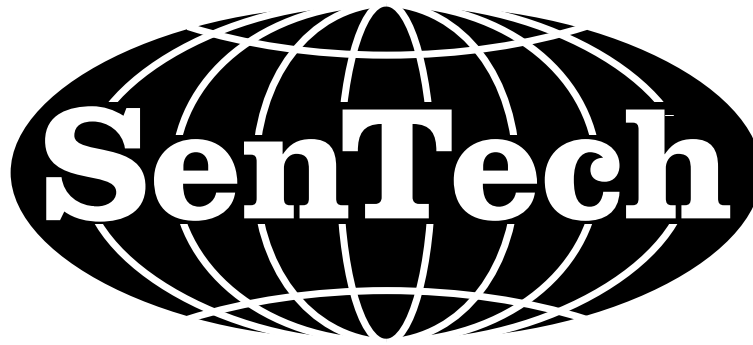

SenTech, gives the following as its complete Limited Warranty Statement:

**SenTech
Manufacturer's Limited Warranty**

SenTech warrants to the original purchaser-user that its equipment, as originally supplied, is free from defects in materials and workmanship and will perform adequately under normal use and service, subject to the following conditions and limits:

If the equipment or any part or parts thereof prove to be defective in normal use, then such item or parts will be repaired or replaced at the option of **SenTech** by **SenTech**, provided that notice of such defect is given by original purchaser-user to **SenTech** within one (1) year from the date of original installation of the equipment.

Warranty is made on condition that such original purchaser-user has returned to **SenTech** the warranty registration form applicable to the equipment, duly and fully completed, within thirty (30) days of the date of purchase by the original purchaser-user.

SenTech's obligation under this warranty is limited exclusively to replacing without charge, or to repairing, at **SenTech's** option, upon return to Indianapolis, Indiana, transportation charges prepaid, any part or parts that shall be found to be defective in material or workmanship during the warranty period. Charges for labor (except for labor performed by **SenTech** factory for repairing defective parts) are not covered and these, plus all other costs and expenses for transportation, insurance, etc., shall be paid for by the Warrantee. If, upon inspection by **SenTech** or its Authorized Service Representative, it is determined that the equipment has not been used in an appropriate manner as described in the **SenTech** Operator's Manual or has been subject to misuse, alteration, accident, damage during transit or delivery, or that such part is from a machine on which the serial number has been altered or removed, then this warranty is void and of no further force or effect. All decisions regarding the existence of defects in material or workmanship or other causes shall be made by **SenTech's** Factory Representative and shall be final and binding upon the parties. Returns shall only be made upon the prior written authorization thereof by **SenTech**.

THE FOREGOING LIMITED WARRANTY IS EXPRESSLY MADE IN LIEU OF ANY AND ALL OTHER WARRANTIES, EXPRESS OR IMPLIED, INCLUDING WITHOUT LIMITATION ANY IMPLIED WARRANTY OF MERCHANTABILITY OR FITNESS FOR A PARTICULAR PURPOSE.

The foregoing limited warranty shall not be enlarged or affected by, and no liability or obligation shall arise from, **SenTech's** rendering of technical or other advice, or service, in connection with any of its equipment or parts. Employees, agents, distributors, retailers, and sales representatives are not authorized to make warranties. Oral or written statements made may they do not constitute warranties and shall not be relied upon.

REPLACEMENT OR REPAIR OF DEFECTIVE EQUIPMENT OR PARTS AS PROVIDED ABOVE IS THE ORIGINAL PURCHASER-USER'S SOLE AND EXCLUSIVE REMEDY FOR CONTRACT, WARRANTY, NEGLIGENCE, TORT OR STRICT LIABILITY CLAIMS FOR ANY LOSS, DAMAGE OR EXPENSE ARISING OR ALLEGED TO ARISE OUT OF THE DESIGN, MANUFACTURE, SALE, DELIVERY OR USE OF SUCH EQUIPMENT AND/OR PARTS. IN NO EVENT SHALL SENTECH BE LIABLE FOR ANY AMOUNT IN EXCESS OF THE PURCHASE PRICE OF THE EQUIPMENT, OR FOR LOSS OF USE OR PROFITS, LOSS OF BUSINESS INTERRUPTION, ATTORNEY'S FEES, OR CONSEQUENTIAL, CONTINGENT, INCIDENTAL OR SPECIAL DAMAGES CAUSED OR ALLEGED TO CAUSED IN WHOLE OR IN PART BY THE NEGLIGENCE, TORT, STRICT LIABILITY, BREACH OF CONTRACT, BREACH OF WARRANTY, OR OTHER BREACH OF DUTY OF OR BY SENTECH.

SenTech Corporation
5745 Progress Road
Indianapolis, Indiana 46241

THIS LIMITED WARRANTY IS NOT TRANSFERABLE.

Warranty Information

Fill out the CTS/Warranty form and return to Sentech.

Replacement Parts

When ordering replacement parts, specify the part numbers, give the description of the part, the model number and the serial number of the machine.

Parts Order Procedure

Always order parts from your SenTech dealer. If for some reason you cannot contact your dealer, you may order directly from the factory. Be sure to use the following order procedure:

1. Order on your purchase order letterhead.
2. Specify shipping instructions. If any order is received without specific shipping instructions, the order will be shipped best way.
3. Indicate the quantity desired, the part number, and the part description.
4. Always indicate the model number and the serial number of the machine for which the part is being ordered. In the back of this manual is an exploded view drawing and parts list of your SenTech machine. This will aid you in ordering parts.
5. Regular mailed orders normally take three (3) days to process and ship.
6. All prices are subject to change without notice.
7. Parts Terms: All parts will be sent c.o.d. unless previous billing arrangements have been made. Customer is responsible for all freight and c.o.d. charges.
8. All shipments are made f.o.b. Indianapolis. By acceptance of a package, the carrier assumes liability for its deliveries to the customer in good condition. If a package is lost or damaged, immediately file a claim with the carrier, not SenTech.

Parts Return Procedure

1. No warranty parts shall be returned to SenTech without written authorization from the factory parts department.
2. When any part is returned to SenTech for any reason, such part must be properly identified.
3. Parts returned without proper identification will be kept for a reasonable period of time and disposed of as seen fit. In such cases, no credit will be issued.

4. Nondefective parts will be returned to the customer at the customer's expense.
5. If a letter is written pertaining to any refund part, this letter should be attached to the package containing the part.
6. All correspondence pertaining to parts must be directed to the SenTech Parts Department at:

SenTech
5745 Progress Road
Indianapolis, Indiana 46241

7. All parts are sold f.o.b. factory.
8. Parts returned "collect" will be refused by our shipping department.

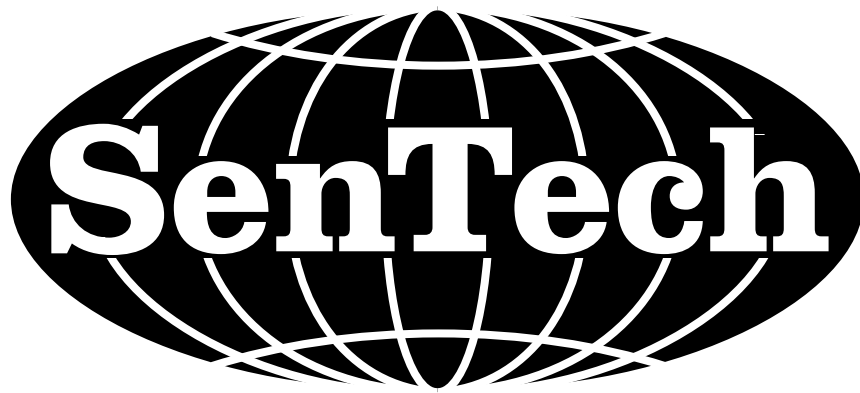

P/N 400228
09/15/95